

# Bray<sup>®</sup> CONTROLS



**ELECTRIC**  
Actuators & Accessories



Series 70  
Sizes 003-065



Series 70  
Sizes 130-181

## ELECTRIC ACTUATORS

Series 70	Torque Output	
	Lb-Ins	N-m
003	300	34
006	600	68
008	800	90
012	1200	136
020	2000	226
030	3000	339
050	5000	565
065	6500	735
130/131	13000	1469
180/181	18000	2034
S70 - Explosion Proof Models		
708	800	90
712	1200	136
720	2000	226



# Bray<sup>®</sup> CONTROLS

## INTRODUCTION

Through years of field application experience, research and development, we have designed products that meet the stringent requirements of today's process industries. Bray has earned a reputation of excellence by creating products of superior value and quality, providing personalized customer service and on-time deliveries. Our success has always been the direct result of our fully integrated, full range butterfly valve and control product lines. Rugged and reliable, our products are engineered to provide years of trouble free service.

**Bray products are used in a wide range of industries worldwide including:**

- Chemical
- Beverages
- Pharmaceuticals
- Food Processing
- Petroleum Refining & Oilfield
- Transportation
- Microprocessors
- Marine
- Pulp & Paper
- Mining
- Power/FGD
- Irrigation
- Water & Wastewater Treatment
- Textile
- Desalination
- Steel Production
- Sugar/Ethanol
- HVAC
- Breweries/Wineries



## PRODUCT QUALITY & PRECISION

Assuring product quality, precision manufacturing and internal process integrity, Bray Controls has been certified to ISO 9001 quality standard. The certification of compliance was issued by Lloyd's Register Quality Assurance (LRQA), a worldwide independent certifier. The basis for Bray Controls high level of quality assurance are the quality control guidelines and procedures submitted, reviewed and approved in accordance with criteria established within ISO 9001:2008 and EU Directives.

*“Bray Controls is focused on and committed to meeting the expectations and needs of our customers while continually improving the effectiveness of our quality management.”*

- All Bray valves are pressure tested to 110% of rated pressure to assure bubble-tight shutoff.
- All Actuators are calibrated and cycle tested before shipment. Pneumatic actuators are also pressure tested to assure no leakage.
- Material Traceability - Certification is provided for all valves upon request for all pressure retaining components.
- Positive Material Identification - All materials are subjected to PMI testing to verify material traceability certificate.

*A complete listing of approvals & certifications can be found at [www.bray.com](http://www.bray.com).*

# BRAY SERIES 70 ELECTRIC ACTUATOR

Output Torque 300 Lb-in (34 N-m) to 18,000 Lb-in (2,034 N-m)

Bray Controls' years of proven success in electric actuation, combined with innovative engineering, has produced the Series 70. The Series 70 features on-off or modulating control.

Bray's Series 70 electric actuator has many advantages over other actuators including:

- UL, CSA and CE certification of most units
- Wiring directly to the terminal strip without interference from other components
- Simple and unique manual override handwheel system
- Lowest profile and lightest weight actuator on the market
- Simple finger or screw driver adjustment of travel limit cams without interference from other components
- Highly visible valve status display on most units

Designed like a junction box, the Series 70 offers by far the easiest access to terminal block wiring, cam adjustments and switch installation. Therefore, the time required for field start-up and adjustment is greatly reduced, and maintenance can be performed with assured ease and safety.

## EXPLOSION PROOF ENCLOSURE

The Series 70 optional waterproof/explosion proof unit is UL listed and certified to NEMA 4, 4x and specifications for USA & Canadian hazardous locations Class I Div 1&2 Groups C&D; Class II Div 1&2 Groups E, F&G. The rugged, heavy duty housing contains precision machined bores and flanges to meet flame path requirements. Waterproof/Explosion proof models are currently available with 800 to 2,000 lb-in output torque, continuous or intermittent duty.



**TRAVEL LIMIT SPDT SWITCHES:** Bray has provided two SPDT mechanical switches as standard. These durable, high quality switches are mechanically isolated and electrically independent. The dedicated circuits eliminate any voltage crossover between the switches. This switch combination is used for both open and closed positions of the valve and requires only one cam for each direction of valve travel. Bray's design provides synchronicity between motor control and position display. Switches are easily accessible without interference from other components. Each switch is marked with open or close labels and the cams are color coded, green for open and red for close, eliminating the possibility of incorrect wiring.

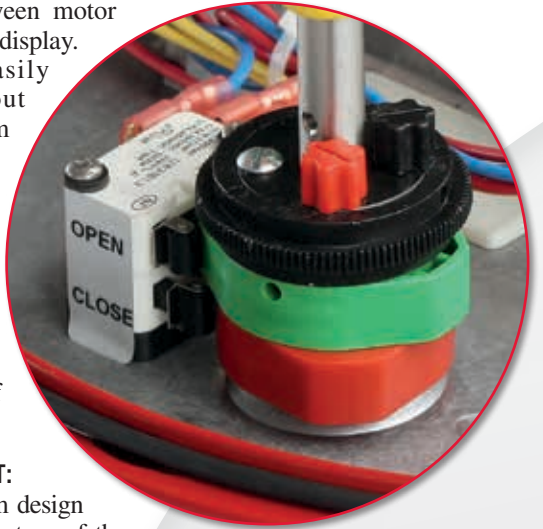

### CAM ADJUSTMENT:

Bray's patented cam design is an outstanding feature of the Series 70. Cams for each switch are infinitely adjustable by finger touch or screwdriver with no special tools needed. The adjustment knobs rotate the specially formed cams. Each cam is color coded – the red adjustment knob controls the red cam (close position), and the green knob controls the green cam (open position). Standard factory setting allows 90° travel between open and closed positions.

**CONDUIT ENTRIES:** Two connections in either NPT or metric threads. One entry is for power, the other for control wiring.



**TERMINAL BLOCK:** The actuator switches are pre-wired to an easily accessible terminal block. Terminals are clearly identified for customer wiring. The block has been placed near the two conduit entries with ample room for running wire leads. A wiring diagram is included inside the cover for easy reference. The ground wire screw is plated green and positioned for easy access.

**VALVE STATUS DISPLAY:** Prominently labeled and color coded – yellow for open, red for closed – the display indicates valve position through the full range of travel. The display can be seen from almost any angle. Made of high impact, heat and chemical resistant clear polycarbonate, this display withstands caustic wash down and offers excellent corrosion protection. Potential leak paths are eliminated since the indicator cover utilizes a static seal, not a dynamic seal.

**INTERPOSING RELAY:** The time delay provided by the Interposing Relay will protect the switches and gears from the controller's instantaneous command signal reversal. This feature also allows for parallel wiring of multiple actuators.

**MANUAL OVERRIDE:** A manual override handwheel is standard on all models to rotate the valve without electrical power. A yellow caution stripe around the handwheel hub becomes visible when the handwheel is engaged for manual operation.

**AUTOMATIC POWER CUTOFF SWITCH:** The Series 70 is supplied with a SPDT mechanical switch which cuts power to the motor when the handwheel is engaged for manual operation.

**O-RING SEAL FOR WATERTIGHT ENCLOSURE:** The large seal between the cover and base provides a waterproof seal and prevents internal corrosion. The Bray Series 70 O-ring seal is a far superior design to commonly used gaskets.

**ENCLOSURE:** The Series 70 waterproof unit is UL listed Type 4, 4x. Die-cast aluminum cover and base are high-quality polyester powder coated for exceptional corrosion, wear, impact and ultra-violet resistance

**CAPTIVE COVER BOLTS:** The cover is attached to the base by stainless steel bolts. When the cover is removed the bolts are held captive in the cover. This prevents time consuming problems caused from lost or misplaced bolts.



## **BRAY SERIES 70**

### **POWER CENTER**

Bray designed the Series 70 to completely separate the Control Center from the Power Center. The Power Center, located in the actuator base, consists of motor, gear train, capacitor, output drive and heater. This design protects the power drive system as each component has been engineered to require no customer servicing. The Power Center components have been uniquely configured to maintain the extremely low profile of the Series 70.

**SELF-LOCKING OUTPUT DRIVE ASSEMBLY:** The output drive assembly features a self-locking worm and worm gear drive which holds the valve in the desired position without the need for electro-mechanical braking systems. The worm shaft directly drives the worm gear.

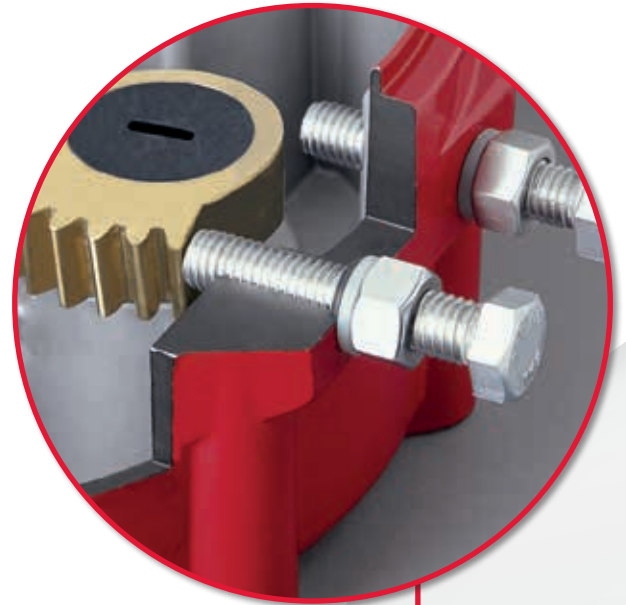

### **MECHANICAL TRAVEL STOPS**

Stainless steel mechanical travel stops are field adjustable to prevent over travel when manual override is in use. The travel stops are located outside the base for easy readjustment without removing the cover. Stainless steel lock nuts with O-ring seals hold the travel stops securely in place. The travel stops are normally set at the factory to allow 0° and 90° travel.

*Sectional view of  
the manual override.*

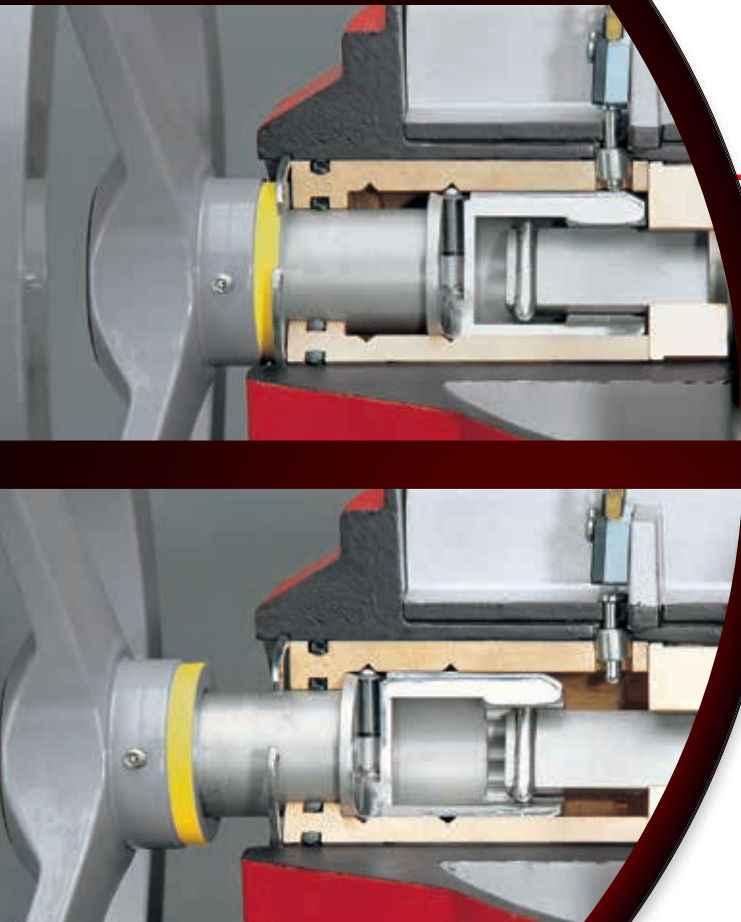

### **MANUAL OVERRIDE HANDWHEEL ASSEMBLY**

- Pull to engage for manual operation.
- Rotate handwheel to position valve.
- Push to return power operation.

The Bray manual override system ensures positive and fast manual operation without the use of extra tools or levers. When the handwheel is engaged, the electrical power to the motor is cut off by means of the Automatic Power Cutout Switch. When engaged, the manual override shaft is held in position by a Ball Detent. The Ball Detent also holds the shaft in position when the handwheel is pushed in to disengage the override. The Drive Pin engages and disengages the manual override shaft from the worm and segmented worm gear output shaft. When the handwheel is pushed or pulled, the drive pin smoothly engages the worm shaft.

## ONE PIECE WORM GEAR, DRIVE SHAFT

The drive shaft is the driving member that positions the valve. The worm gear drives the valve status display shaft which operates the infinitely adjustable cams to limit the electrical travel of the actuator.



**MOTOR:** 115 or 220 VAC single phase permanent split-capacitor reversible induction motor. The motor features a built-in thermal overload protector of a bi-metallic strip in the windings set at 275°F (135°C) with automatic reset.

**WORM SHAFT**

**DISC SPRINGS**

**GEAR TRAIN:** The heavy-duty spur gear train is composed of precision cut, multi-staged gears and shafts. The gears and shafts are heat treated high alloy steel. The gear train is permanently lubricated at the factory.

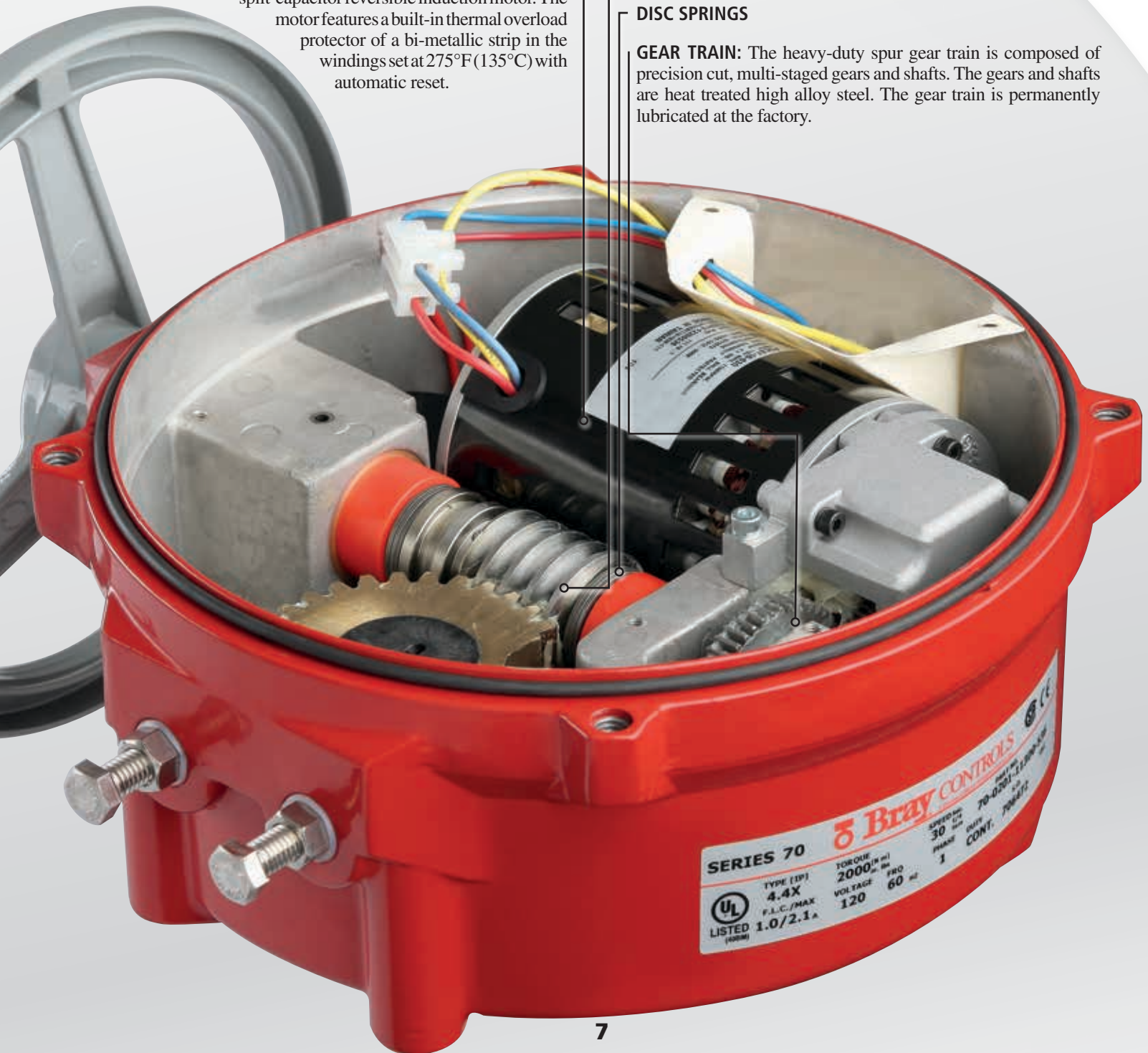

**SERIES 70**

UL LISTED (4000) TYPE (IP) 4.4X F.L.C./MAX 1.0/2.1A

TORQUE 2000 (in-lb) VOLTAGE 120

FREQ 60 Hz

SPEED 30 RPM

PHASE 1

CONT. DUTY

**Bray CONTROLS**

70-0201-11000000

# BRAY SERIES 70

## MODULATING ACTUATOR - SERVO PRO

The Bray Series 70 Electric Actuator can be equipped with a Servo Pro for precise control of valve position. The Servo Pro consists of a microprocessor controlled circuit board and a feedback potentiometer assembly, which both fit entirely within the standard Series 70 actuator housing. The circuit board has terminal blocks for customer field wiring, and other terminals for internal connections to the actuator components. The feedback potentiometer is driven by a gear set connected to the actuator output drive. Also available are servos capable of serial BUS communication, such as DeviceNet.

**VOLTAGE SPIKE PROTECTION:** Voltage spikes that can damage electrical equipment are very common in industrial locations. Large voltage spikes can be caused by switching power loads, such as large motor drives, at the customer location. The output stage triacs of the Servo Pro are protected against damage from voltage spikes by a special combination of:

- Limit Switch Circuitry
- Metal Oxide Varistor (MOV)  
For Transient Voltage Suppression
- Zero Crossing Detection

**DeviceNet SERVO PRO:** Bray also offers the Series 70 with the most advanced serial BUS communication Servo on the market. The Bray DeviceNet Servo Pro is fully ODVA (Open DeviceNet Vendor Association) compliant. Benefits include greatly simplified field wiring and installation, advanced control and diagnostics in real-time from a remote location, and full network integration. Please contact your Bray representative for more information.

### SERVO PRO FEATURES / SPECIFICATIONS

Servo is available for modulating service, continuous duty actuators only.

<b>Power Input</b>	24 , 120 or 220 VAC, 50/60 Hz (power must match motor)
<b>Power Consumption</b>	2 Watts (not including actuator power)
<b>Input Signal</b>	Standard: 4-20 mA DC Configurable: 1. 0-10 VDC 2. 2-10 VDC 3. 10K Ohm or greater potentiometer,
<b>Calibration</b>	Single Button Autocalibration
<b>Indicators</b>	Power: Green LED Status: Flashing Red / Green LED Motor: Red LED (Close), Green LED (Open)
<b>Control Modes</b>	Standard: Full Range, Direct Acting Configurable: Reverse Acting, Split Range
<b>Fail Position</b> (Loss Of Input Signal)	Standard: Fail Closed Configurable: Fail Open, Fail in Last
<b>Control Characteristic</b>	Linear
<b>Duty Cycle</b>	100%
<b>Internal Feedback</b>	10K Ohm Potentiometer, gear driven
<b>Retransmission Output</b>	Standard: 4-20 mA DC Configurable: 0-5 VDC, 0-10 VDC, 2-10 VDC Retransmission Output is designed to drive an isolated 250–500 Ohm resistive load.
<b>Speed Control</b>	Standard: Full Speed (Speed Control is Disabled) Configurable: Bidirectional–Independent Open and Close Trim Pots adjustment

“Standard” is the way the Servo is set at the factory.

“Configurable” means the customer, or the factory, can modify the Servo by setting DIP switch(es).



**SERVO PRO OPERATION:** The Servo Pro can be configured by the factory or the customer to accept several types of input signals, such as 4-20 mA DC, 0-10 VDC, 0-5 VDC or potentiometer control. Each terminal connection and indicator is clearly labeled to simplify field wiring and operation. The input signal electronically represents the desired actuator position, and the internal feedback potentiometer signal electronically represents the actual actuator position. The microprocessor constantly compares the two signals, and if a difference is detected, drives the actuator in the proper direction until the signals are equal. When a balance is reached, the microprocessor turns off the actuator motor. The worm gear then mechanically holds the valve in the desired position until the input signal is changed again.

**SPEED CONTROL:** Adjustments are configurable for both open and closed speed control of the actuator motor. In addition, an approach control circuit senses when the actuator is about to reach the desired valve position, and pulses the motor to avoid overshooting the set point.

**FEEDBACK POTENTIOMETER:** The feedback potentiometer gear has a green rib which should be aligned with the slot on top of the cam-indicator shaft when in the fully open position. This simple alignment ensures the potentiometer will provide the Servo Pro with continuous, accurate actuator-valve position feedback.

Calibration of the feedback potentiometer is done through a unique gear arrangement that is easily accessible and eliminates the need of any special tools. A simple adjustment of Bray's patented cam drive aligns the potentiometer gear as easily as a travel cam.

**ONE TOUCH AUTOMATIC CALIBRATION**





## **BRAY SERIES 70** OPTIONS

The conduit entry panel has four holes which may be easily tapped for the installation of optional local Control Station.



**CONTROL STATION:** The conduit entry panel has four holes which may be easily tapped for the installation of optional local Control Station. The Control Station features a local-off-remote control switch, an open-stop-close switch, and two lights which locally indicate open and closed valve position. The cover plate can be rotated in any 90° increment, allowing the customer to operate and view the station with ease. The enclosure is aluminum and weatherproof (NEMA Type 4, 4X, IP 65). Additionally, the control station has captive cover bolts and two cable entries available in the following thread connections: 3/4" NPT or M25. Two different multi-pin, watertight electrical cable connections are also available.



**BATTERY BACKUP:** To meet consumer needs, Bray Controls has developed the Battery Backup Unit (BBU) for the 24 VAC Series 70 Electric Actuator. In the event of power failure, the BBU will switch the actuator to battery power to reach its fail-open or fail-closed position. After the actuator has reached its fail position, the BBU turns off until external power is restored. Once external power has been restored, the actuator returns to the control device's command position.

- **Power Requirements:** 24 - 27 Volts AC for full charge battery condition.
- **Battery Conservation Mode:** Turns the BBU off when the actuator has gone to the programmed fail position. The charging circuit prevents over charging of the batteries.
- **Easily Configured:** Field selectable control circuit.

- **Battery Monitoring Feature:** Includes a local green LED indicator light on the BBU cover which lights up when the batteries are adequately charged and functional. A normally open dry contact is included that may be used to operate a remote alarm.
- **Dependable:** The two sealed batteries provide more than sufficient power to operate the actuator for its one fail-open or fail-closed cycle.

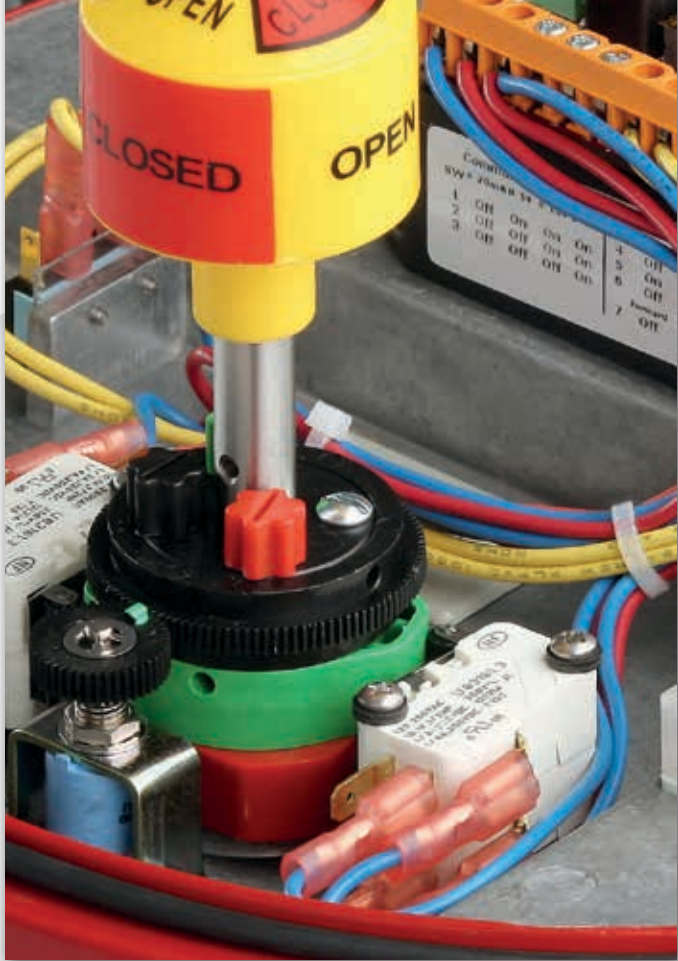

**AUXILIARY SWITCHES:** Independent dry-contact (voltage free) SPDT mechanical switches are available to indicate travel position to remote customer control systems.



**HEATER:** A self-regulating heater can be added to prevent possible damage to electrical components due to condensation build-up inside the actuator. Mounted in the actuator top plate for easy accessibility.



### **ELECTRICAL CABLE CONNECTIONS**

A multi-pin, watertight cable receptacle offers full compatibility with today's industrial wiring systems. Factory pre-wiring prevents errors and allows quick-connect field installation. Cord sets with connection/flying leads or extension cords with connections on both ends can plug directly into the receptacle.

*Torque Limit Switches shown with mounting bracket sectioned for clarity.*



### **MECHANICAL TORQUE LIMITING SYSTEM - optional**

The mechanical torque limiting system consists of a Worm Shaft, a Worm, a set of Torque Disc Springs and a Shaft Groove for torque limiting switches. The torque disc springs, located on each side of the worm, resist the linear movement of the worm shaft. The worm shaft is driven against the torque disc springs in response to output torque. The shaft groove actuates the torque limiting switches, located above in the Control Center, to start and stop the motor. Two SPDT mechanical switches and two factory calibrated set screws independently respond to predetermined loads in both the open and closed travel directions by sensing the movement of the worm shaft, and interrupting the electrical power to the motor. The switches operate at any point of actuator travel. The precisely controlled movement of this system is the main torque limiting element of the Series 70.

